

FICHA TECNICA

REVESTIMIENTO PARED EASY

Material	PVC 100% reciclable. Ligero, duradero y fácil de limpiar.
Acabado	Modelos creados a base de patrones.
Instalación	Montaje muy fácil y rápido gracias al machihembrado. Se pega directamente a la pared con Adhesivo y sin obras.
Colocación	¡Tú eliges! La colocación según tu gusto Horizontal o vertical
Otros tamaños	Se pueden cortar con facilidad, con una sierra estándar o de calar
Durabilidad	Garantía de 5 años
Otras propiedades	Apto para los lugares más exigentes, como el recibidor, la zona de trabajo, baños o la cocina.
Resistencia al Fuego	C-s3

Limpieza y Mantenimiento

- Usar Agua para su limpieza con un detergente suave y un paño. No deje detergentes en la superficie, enjuáguelos completamente después de su limpieza
- No limpiar con paños, esponjas o cepillos afilados o rugosos, se puede rallar la superficie.
- NO usar disolventes, acidos, bases o derivados para su limpieza.
- NO dejar SUCIEDAD LÍQUIDA para que se seque

Normas de uso e instalación

- **Antes de la instalación, es necesario aclimatar las paredes** mínimo 24 h, para ajustar su temperatura a la temperatura ambiente.
- **No aplique las paredes decorativas en lugares expuestos a altas temperaturas (superiores a 60 °C)**, por ejemplo, en **saunas, chimeneas** o cerca de cocinas; tampoco en habitaciones expuestas a fluctuaciones de temperatura superiores a 10 °C o en lugares **altamente** expuestos a la **luz solar**.
- El producto **puede ser instalado en habitaciones húmedas** (cocinas, baños) siempre que esté **sellado con silicona**.
- **No modifique el producto.**
- El producto está diseñado únicamente para **uso en interiores**.
- **No atornille perchas, estantes u otros elementos directamente a los paneles.**

DECLARATION OF PERFORMANCE no. PK/1/2015

1. **Unique identification code of the product-type:** MOTIVO Decorative Wall
2. **Intended use:** Profile PVC-U for interior walls / ceiling finishes
3. **Manufacturer:** Profile VOX Sp. z o.o. Spółka Komandytowa
ul. Gdynska 143, 62-004 Czerwonak, Poland
4. **System of assessment and verification of constancy of performance of the product:** 3
5. **Harmonised standard:** PN-EN 13245-2:2009/AC:2010
6. For a product covered by a harmonised standard, the Building Research Institute, Filtrowa 1; 00-611 Warsaw, Poland (European Notified Body no 1488), the ITB Group of Testing Laboratories performed type testing under system 3 and issued test reports.
7. **Declared performance:**

Essential characteristics	Performance	Harmonised technical specification
Impact resistance	not less than 3J (23,03)	PN-EN 13245-2:2009 / AC:2010
Emissions of volatile substances	A+	
Reaction to fire	C-s3;d0	
Resistance to fixing	see: installation instructions	

8. The performance of the product identified above is in conformity with the declared performance in point 7. This declaration of performance is issued in accordance with Regulation (EU) no. 305/2011 under the sole responsibility of the manufacturer identified in point 4.

Signed for and on behalf of the manufacturer by:

Profile Vox Sp. z o.o. Sp. k.
PL-62-004 CZERWONAK, ul. Gdynska 143
tel. +48 61 812-05-11, fax +48 61 812-06-61
NIP 7772776017, REGON 634591881
(27)

Czerwonak, 14.09.2015

Robert Skrobisz
General Director
DYREKTOR GENERALNY

Robert Skrobisz
page 1/1

GUARANTEE

MOTIVO WALL SYSTEM

Place	
Date of sale	Distributor's stamp and signature

§1. General Provisions

1. Profile Vox spółka z ograniczoną odpowiedzialnością sp. k. with its registered office in Czerwonak, ul. Gdyńska 143, 62-004 Czerwonak, entered into the Register of Entrepreneurs of the National Court Register kept by the District Court Poznań-Nowe Miasto and Wilda in Poznań, 8th Commercial Division of the National Court Register under the KRS number 0000210637, REGON 634591881, Tax Identification Number 7772776017, Waste Database: 000002790, telephone number 695 540 190, hereinafter referred to as the "Guarantor", warrants that its:

WALL PANELS

hereinafter referred to collectively as the "Product", are intended to be used for finishing the walls of buildings, and their properties are specified in detail in the relevant Declaration of Performance available at www.vox.pl, which states the fitness of the Product for use.

2. In the event of defects being found in a Product within 5 (five) years from the date of purchase of the Product, the Guarantor shall, at its sole discretion, repair the Product or replace the defective Product/the defective part of the product with a defect-free Product/part or refund the full price or part of the price paid for the Product. In the event of a substantial repair or replacement of the Product with a defect-free Product under this Guarantee, the period of the Guarantee for the replaced or repaired Product shall begin anew, starting when the defect-free item is delivered to the Purchaser or when the repaired item is returned to the Purchaser. If the Guarantor replaces a part of the item, the above shall apply mutatis mutandis to the replaced part. In other cases, the period of the Guarantee is extended by the period of the Guarantor's service performance during which the Purchaser could not use the Product. In the case of refunding the full price, the Guarantor may require the Purchaser to first transfer ownership of the Product to the Guarantor and hand over the Product to the Guarantor.
3. This Guarantee does not exclude, limit, or suspend the Purchaser's rights under the provisions on warranty for defects of a sold item (Article 579 of The Civil Code of 23 April 1964, consolidated text ([Polish Journal of Laws] Dz.U of 2020 item 1740, as amended.)
4. The Guarantee is given on the territory of the country in which the Product was delivered to the first Purchaser.
5. The date of purchase of the Product shall be the date on which the Product is handed over to the Purchaser.

§2. Transfer of Rights

1. The Creditor of the Guarantee is a Purchaser who purchases the Product for the purpose of using it, excluding any Purchaser who purchases the Product in the course of their own business activities for resale ("Creditor of the Guarantee" or "Purchaser").
2. In the event of a change of the authorised user of the property on which the Product is installed, the Guarantee shall pass to the new authorised user in accordance with the terms of this Guarantee, provided that the new authorised user presents this Guarantee (stamped and signed) to the Guarantor.

§3. Guarantor's Liability Limitation

1. The Guarantor shall not be liable for Product defects and damage resulting from external factors that occurred after the Product was delivered to the Purchaser (the Guarantor recommends insuring the Product subject to this Guarantee against the effects of external factors), in particular related to:
 - use of the Product contrary to the Product installation and user manual delivered with the Product or its storage and transport prior to installation,
 - installation which does not comply with the Product installation and user manual,
 - use of accessories not provided for in the Product installation and user manual,
 - impact of foreign bodies exceeding the level specified in the Document indicated in § 1(1),
 - fire, earthquake, flooding, lightning, strong wind, hail, effects of extremely high or low air temperatures, or other events that might be classified as force majeure,
 - defects, faults, or other damage to the building or material on which the Product is installed, caused in particular by factors such as movement, deformation, cracking, or the subsidence of the wall, material, or foundation of the building,
 - discolouration caused primarily by airborne contaminants (including metal oxides or metal particles), mould, exposure to harmful chemicals.
2. The Guarantor is only liable for defects caused by reasons inherent in the Product.
3. This Guarantee does not apply to a Product to which the Purchaser has applied any other, non-factory, coating (e.g., paint, varnish, or plaster) or any Product otherwise modified/ altered by the Purchaser.
4. In the event of replacement of the Product or any of its components under this Guarantee, where the Product installed by the Purchaser is no longer manufactured by the Guarantor or has been modified by the Guarantor, the Guarantor shall be entitled to use the closest equivalent (in terms of type and technical parameters) of the originally installed Product.

§4. Obligations of the Creditor of the Guarantee

1. The Creditor of the Guarantee should notify the Guarantor of any defects in the Product as soon as a defect justifying a claim under the Guarantee is discovered.
2. Any claim under the Guarantee must be made to the Guarantor through the retailer from whom the Product was purchased.
3. A claim under the Guarantee should include a description of the defect, the address where the Product has been installed, the claimant's contact details (name, surname, home address, telephone number, e-mail address – if available) and, if possible, photo documentation showing the defect. By providing their e-mail address, the Purchaser agrees to receive a reply from the Guarantor by e-mail to the e-mail address provided, if the Guarantor responds to the claim in this form, and information relating to the course of the complaint procedure. When the Purchaser makes a claim through the retailer from whom the Product was purchased, the Purchaser may also be asked to provide other data, including personal data required for the complaint handling process.
4. For claims under the Guarantee to be processed, this document, bearing the seal and signature of the seller (distributor) of the Product, with the name of the place, name of the seller, and the date of sale of the Product, must be attached to the claim.

5. The Guarantor will provide information on the result of claim processing, in writing, by e-mail or post, no later than 14 days from the date of the claim, provided that the claim can be processed on the basis of photographs of the Product defect provided by the Purchaser. The Guarantor stipulates that the processing of the claim may require a visual inspection of the Product at the place of installation (with respect to an installed Product), which entails the obligation for the Purchaser to provide access to the property on which the Product under the Guarantee has been installed. In this case, the claim will be processed within 14 days of the claim and of the property on which the Product has been installed being made available to the Guarantor for inspection. The Guarantor will contact the Purchaser (by telephone or e-mail) as soon as possible, but no later than 14 days from the date of the claim, in order to set an inspection date. The inspection shall be carried out by an authorised representative of the Guarantor. The Purchaser shall provide the Guarantor with all the information and documentation necessary to properly prepare and carry out the inspection. As part of the visual inspection, the Guarantor is entitled to take a sample of the Product. For a Product that is not installed, in the event that it is not possible to process a claim on the basis of the photographs sent, or in the event that the Creditor of the Guarantee is unable to send them, the Creditor of the Guarantee shall deliver a sample of the Product, at the Guarantor's expense, to the address: Profile VOX sp. z o.o. sp. k., Quality Department, ul. Gdyńska 143, 62-004 Czerwonak. The Guarantor will contact the Purchaser (by telephone or e-mail) as soon as possible, no later than 14 days from the date of the claim, in order to communicate that the claim cannot be processed on the basis of the photos sent and that a sample of the Product must be provided to the Guarantor. The sample of the Product shall be delivered no later than 7 days after receipt of the above information from the Guarantor. In the event that the Creditor of the Guarantee is unable to send photographs, the Creditor of the Guarantee shall provide a sample of the Product within 7 days from the date of the claim under the Guarantee without the having been advised by the Guarantor to provide a sample of the Product. In the above cases, the period of 14 days for processing a claim under the Guarantee starts from the date the claim is made and a sample of the Product is provided to the Guarantor.
6. In the event that the Purchaser's claim is considered legitimate, the Guarantor shall perform its obligations set out in §1(2) of this Guarantee within 60 days from the date of informing the Purchaser of the result of claim processing as set out in section 5. At the same time, the Guarantor stipulates that due to the specific nature of the production process, the aforementioned 60-day deadline for the performance of the Guarantor's obligations may be extended by the time necessary to produce and deliver components for the replacement or repair of the Product, but by no longer than 80 days.
7. All parts and components of the Product replaced under the Guarantee become the property of the Guarantor on the day they are replaced by other parts and components.
8. The Guarantor does not agree to the use of out-of-court complaint and claim assertion procedures.
9. In matters of the Guarantee, the Creditor of the Guarantee may contact the Guarantor by post (the Guarantor's delivery address as indicated in §1(1) of the Guarantee), by e-mail (e-mail address: reklamacje.profile@vox.pl), or by telephone: 695 540 190.

Data Privacy Notice

1. The personal data Controller is Profile Vox spółka z ograniczoną odpowiedzialnością sp. k. with its registered office in Czerwonak, ul. Gdyńska 143, 62-004 Czerwonak, entered into the Register of Entrepreneurs of the National Court Register kept by the District Court Poznań-Nowe Miasto and Wilda in Poznań, 8th Commercial Division of the National Court Register under the KRS number 0000210637, REGON 634591881, Tax Identification Number 7772776017, Waste Database: 000002790 (hereinafter: Controller.)
2. The Controller appointed a Data Protection Officer to supervise the correctness of personal data processing, who can be contacted by:
 - post, at: Profile VOX sp. z o.o. sp. k., ul. Gdyńska 143 62-004 Czerwonak,
 - e-mail, at: iod@vox.pl
3. The Controller processes personal data in order to process and satisfy guarantee claims (Article 6(1)(b) of the GDPR) and to investigate or defend against possible claims (Article 6(1)(f) of the GDPR).
4. Personal data will be processed for the time necessary to fulfil the purposes for which it was collected, but no longer than 6 years counted from the date of expiry or termination of the contract.

5. Personal data may be disclosed to:
 - entities belonging to the VOX Capital Group,
 - trusted subcontractors, in particular to entities providing and operating selected IT systems and solutions (including hosting, development, and maintenance of IT systems and websites),
 - entities who inspect the product and entities hired to repair or replace the product,
 - providers of accounting and tax services,
 - courier and postal service providers, debt collection agencies, and law firms.
6. Personal data processed by Profile VOX sp. z o.o. sp. k. may be transferred outside the European Economic Area (EEA), i.e., to
 - the USA – On the basis of standard data protection clauses adopted by the Commission in accordance with the verifying procedure,
 - Belarus – On the basis of standard data protection clauses adopted by the Commission in accordance with the verifying procedure.
7. In connection with the processing of personal data by Profile VOX sp. z o.o. sp. k., the data subject has the right to:
 - access their personal data,
 - rectify their personal data,
 - erase or restrict the processing of their personal data,
 - object to the processing of data,
 - lodge a complaint with the supervisory authority, which in Poland is the President of the Personal Data Protection Office.
8. There is no automated decision-making, including profiling, in the processing of personal data.
9. The provision of data is necessary for the conclusion of the contract and its execution.



Installation and User Manual

1. General Information:

- 1.1. The Motivo decorative wall should be stored indoors, on a dry, flat, stable surface that guarantees no direct contact with the ground, in a horizontal or vertical position, ensuring stable support of the panels over their entire surface (without the risk of bending) at a maximum temperature of 60°C, with no exposure to direct sunlight.
- 1.2. The Motivo decorative wall should be transported in a horizontal position, at a maximum temperature of 60°C.
- 1.3. Prior to installation, the Motivo decorative wall should be seasoned in the room where it will be installed for a minimum of 24 hours, so that its temperature adjusts to the ambient temperature.
- 1.4. Unpack the product and compare colours before installation.
- 1.5. We recommend finishing the Motivo decorative wall with dedicated finishing trims.
- 1.6. Do not use the Motivo decorative wall in areas exposed to temperature that stays above 40°C, e.g., in a sauna, on a chimney, next to a cooker, in rooms exposed to temperature fluctuations above 10°C; areas with strong sunlight.
- 1.7. The Product can be installed in damp areas (kitchen, bathroom), providing it has been sealed with silicon. The Product can be mounted on ceilings.
- 1.8. Do not modify the Product by treating its surface or covering it with another material.
- 1.9. If there are any visible defects in the Product or if you notice any irregularities, report these immediately to the dealer before installation.
- 1.10. All principles listed in the installation and user manual should be adhered to. Non-compliance with the instructions causes the loss of product guarantee.
- 1.11. Product for indoor installation only.
- 1.12. The Product is 100% recyclable.

2. Installation

- 2.1. The Motivo decorative wall should be installed on a frame or using adhesive, and in the case of installation on a ceiling – with adhesive and staples.
 - 2.2. The Motivo decorative wall should be installed vertically and on a ceiling.
 - 2.3. The installation should be carried out by persons with basic technical knowledge and knowledge of safety rules.
 - 2.4. The Motivo decorative wall should be installed from left to right, according to the numbering on the back of each panel.
 - 2.5. Put the first panel against the wall/ceiling, check the plumb line and install it, then insert the next panel.
 - 2.6. Before installing the panels on a wall, level the floor.
 - 2.7. Use wedges to align the pattern on the Motivo decorative wall.
- ### Constructing the Frame
- 2.8. The frame should be made of wooden battens fastened directly to the wall.
 - 2.9. All battens should be levelled using a spirit level, so that they form an even plane; use shims or wedges to level the battens if necessary.
 - 2.10. Battens should be laid perpendicularly to the direction of panel installation – if the panels are installed vertically, the battens should be laid horizontally.
 - 2.11. Distance between the battens – 40 cm.
 - 2.12. The battens should be:
 - made of good quality wood, without knots
 - fixed to the wall firmly and securely with screws or other fasteners suitable for the type of surface
 - battens should be left for at least 24 hours in the room they are to be installed in (in order to even out the temperature and humidity).

Installation on a Frame

- 2.13. Fix the panels to the batten using the tongue on the long side.
- 2.14. The staple should adhere so that it does not damage the next panel.

Installation Using Adhesive

- 2.15. The surface must be prepared properly – it must be smooth and dry and cannot crumble.
- 2.16. We recommend using a highly flexible hybrid polymer adhesive for indoor applications and for various building and construction materials, including damp materials, such as concrete, brick, drywall, natural stone, wood and wood-based

products, metals, glass and ceramics, the majority of plastics, for example PVC, expanded polystyrene, polyacrylates, and polycarbonates, e.g., the VOX assembly adhesive.

- 2.17. The adhesive should be applied according to its instructions, in a well-ventilated room.
- 2.18. Apply the adhesive to the panel in an S-shaped motion
- 2.19. For the first panel on a wall, the entire surface needs to be covered with adhesive, with only the lock zones left out.

Installation on a Ceiling

- 2.20. If the panels are installed on a ceiling, we recommend installing – directly on the OSB – using adhesive and staples. The adhesive should be applied over the entire surface of the panel, with only the lock zones left out.
- 2.21. When installing panels on a ceiling, do not push the finishing trim all the way in – leave a 3 mm gap.
- 2.10. Before installing panels on a ceiling, check the level of the OSBs with a spirit level and check the connections between them.
- 2.22. Installation on the ceiling should start with the installation of the finishing trims: B4, B2 (recommended), and B6. Install the trims using adhesive and staples. To join the trims together, cut them at 45° or 90°.
- 2.23. The tongue of the first and last panel should be trimmed (see Fig. Trimming Start-Finish Panels), as close to the chamber wall as possible.
- 2.24. To join panels on the shorter side, use the B3 connector – install it using adhesive and staples.

Cutting the Panels

- 2.25. Conventional carpentry tools for cutting or drilling, such as a hand saw, jigsaw, or table saw, should be used to work on the Motivo decorative wall. Fine-toothed saws should be used; power tools for machining should be used at the same or higher speeds as for woodworking.
- 2.26. When finishing the floor panels with B1-B5 finishing trims, remember to cut off the tongue.

NOTES:

- When installing using adhesive, leave the panels to dry in a well-ventilated room
- In rooms that require the panels to be sealed with silicone, follow the manufacturer's recommendations and allow the panels to dry.

3. Product usage information

- 3.1 The panel should not be subjected to any additional load or be a load-bearing element in a structure.
- 3.2. No hangers, shelves, or any other objects may be screwed directly to the panel
- 3.3. Things can be screwed to the surface under the panel using suitable screws or dowels designed for the type of surface. To do so, drill a hole in the panel.

4. Cleaning and Maintenance

- 4.1. Do not leave liquid stains to dry.
- 4.2. Clean the Motivo decorative wall with water and a light detergent and cloth; do not leave detergent on the surface, rinse thoroughly after cleaning.
- 4.3. Do not clean the Motivo decorative wall with sharp and rough cloths, sponges, or brushes.
- 4.4. Intense scrubbing and the use of strong cleaning agents or leaving detergents on without rinsing can damage the panel surface or cause material discolouration.
- 4.5. Do not use solvents, acids, and bases or agents based on these ingredients for cleaning.

Tools

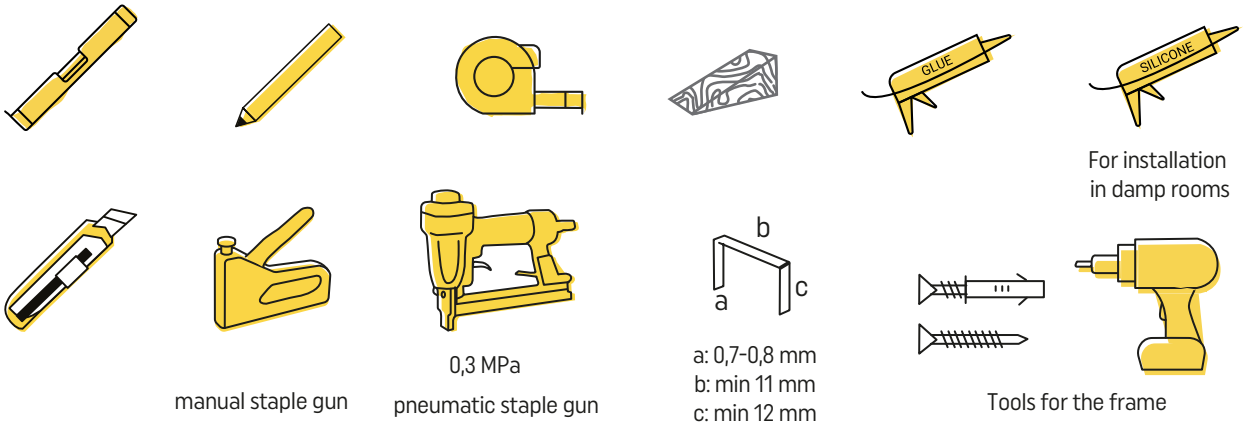

Installation Using Adhesive

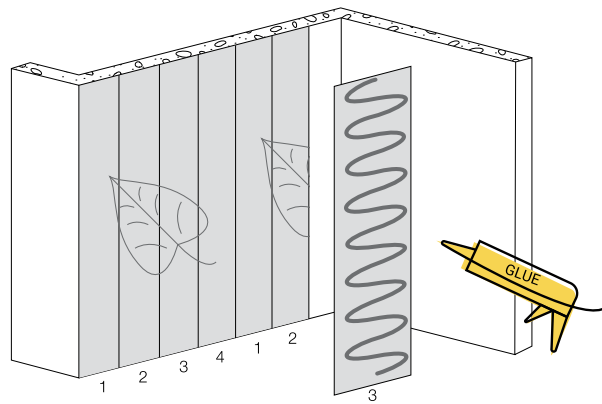

Installation on a Frame

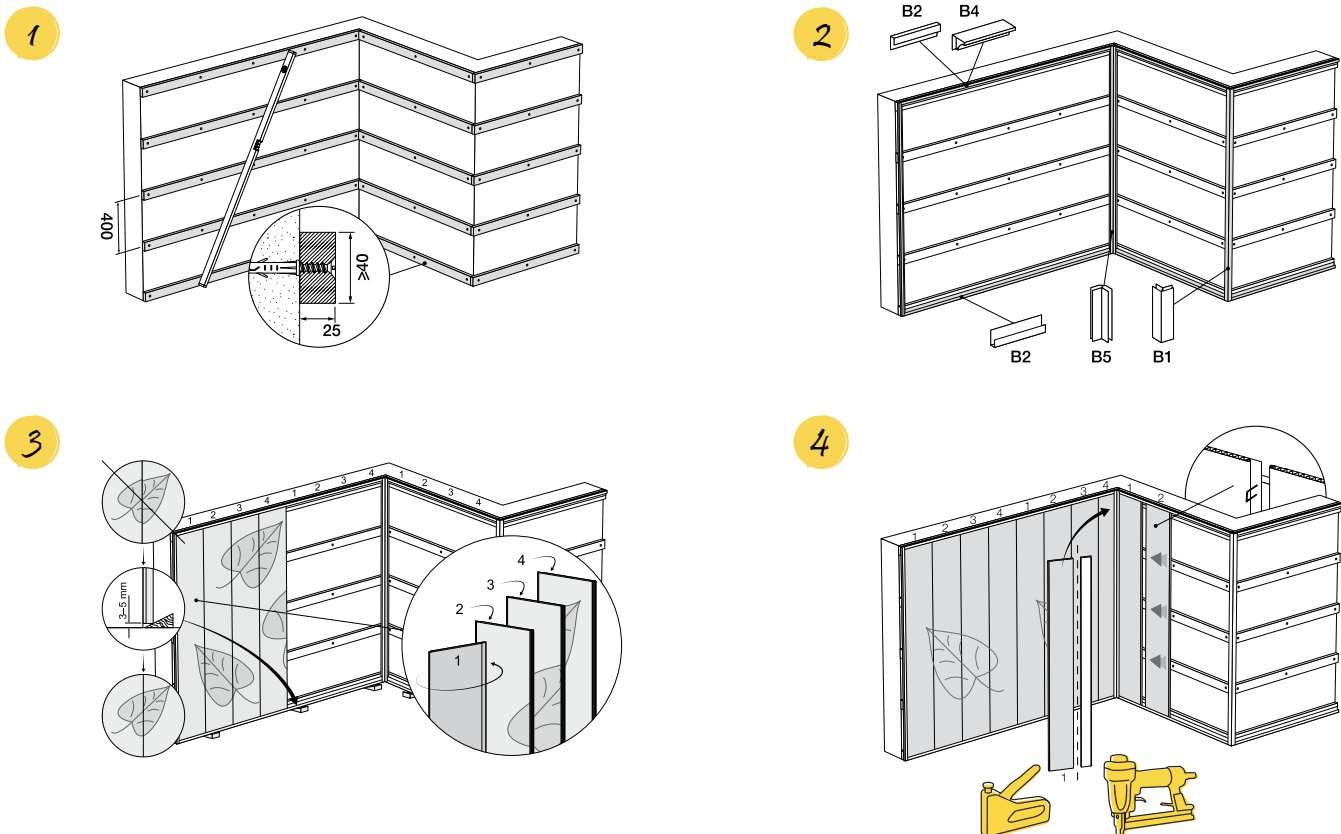

Universal Finishing Trim

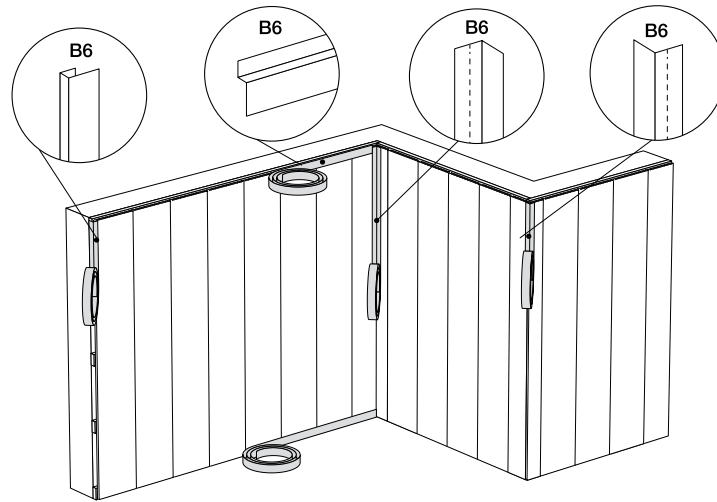

Installation on a Ceiling

1

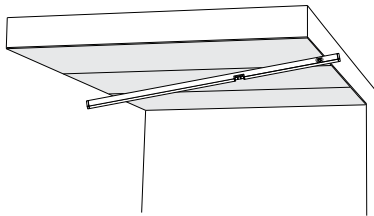

2

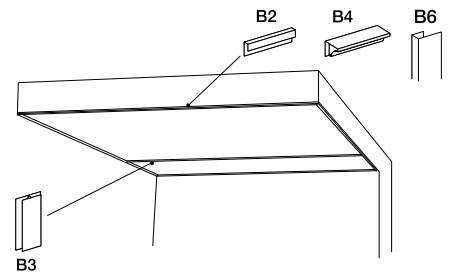

3

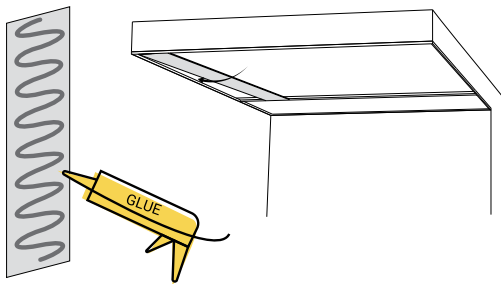

4

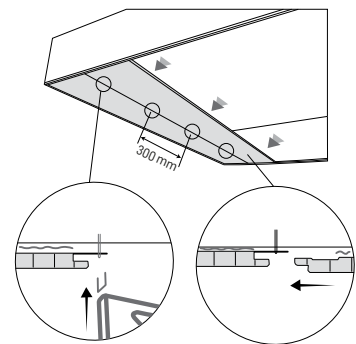

Installation of Finishing Trims

Trimming Start-Finish Panels

